

Esplora Pins

The following provides all the pins that connect to the onboard sensors and what pins the headers provide. For a key to pin names please see the last page.

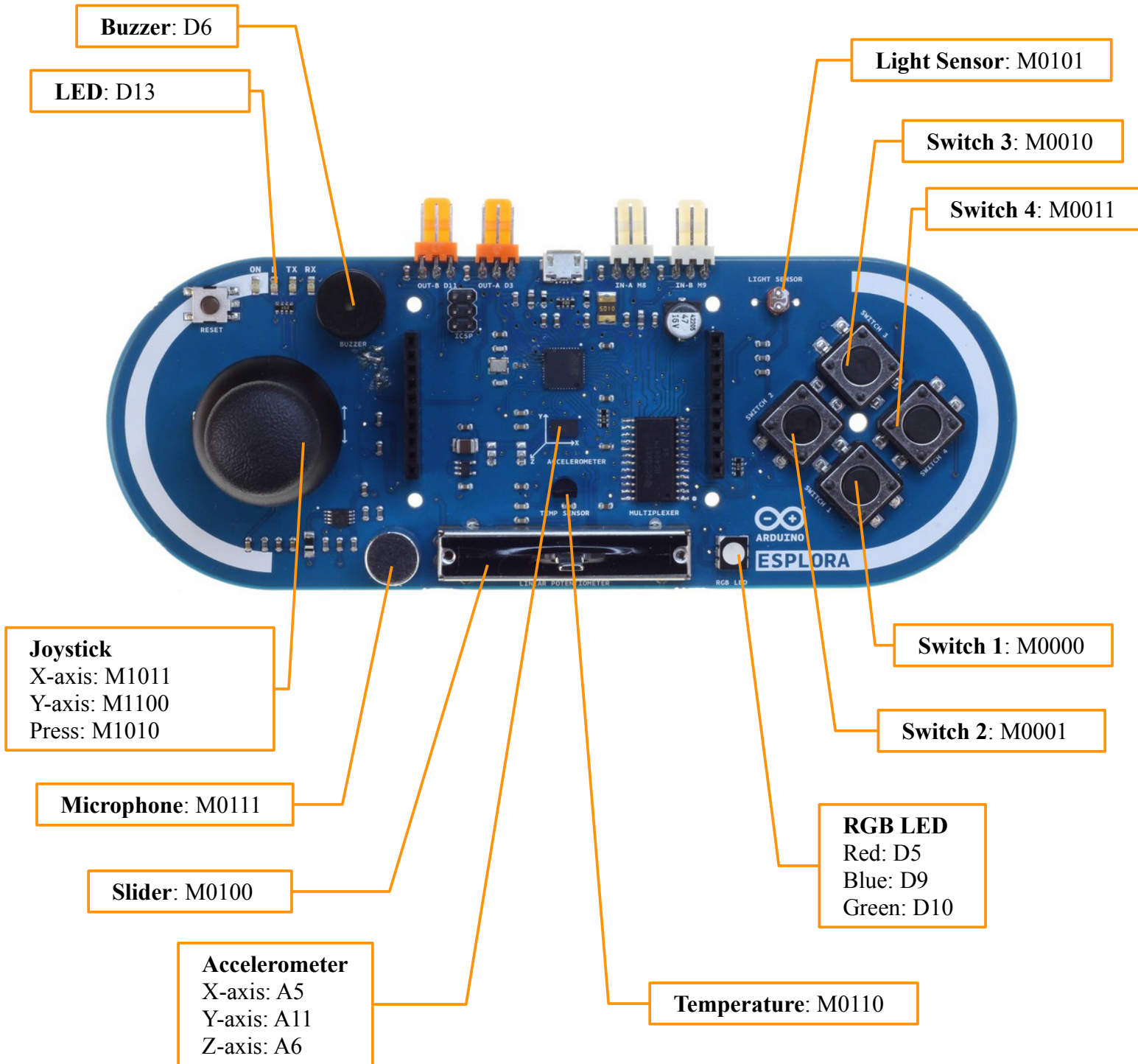

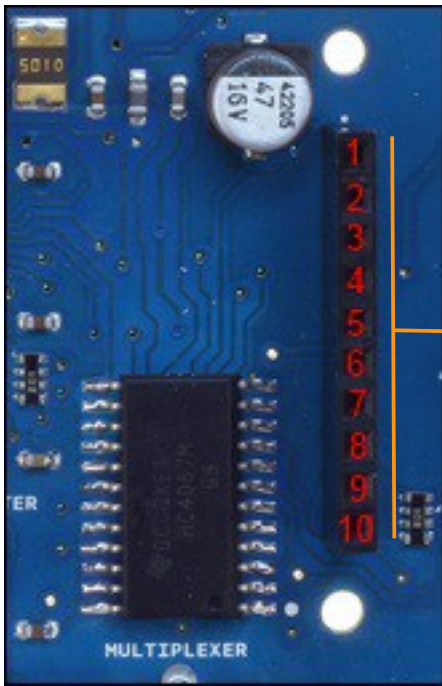

Right Pin Header

1. 5V
2. D14
3. D15
4. D16
5. D7
6. D8
7. D0 / RX
8. D1 / TX
9. 5V
10. GND

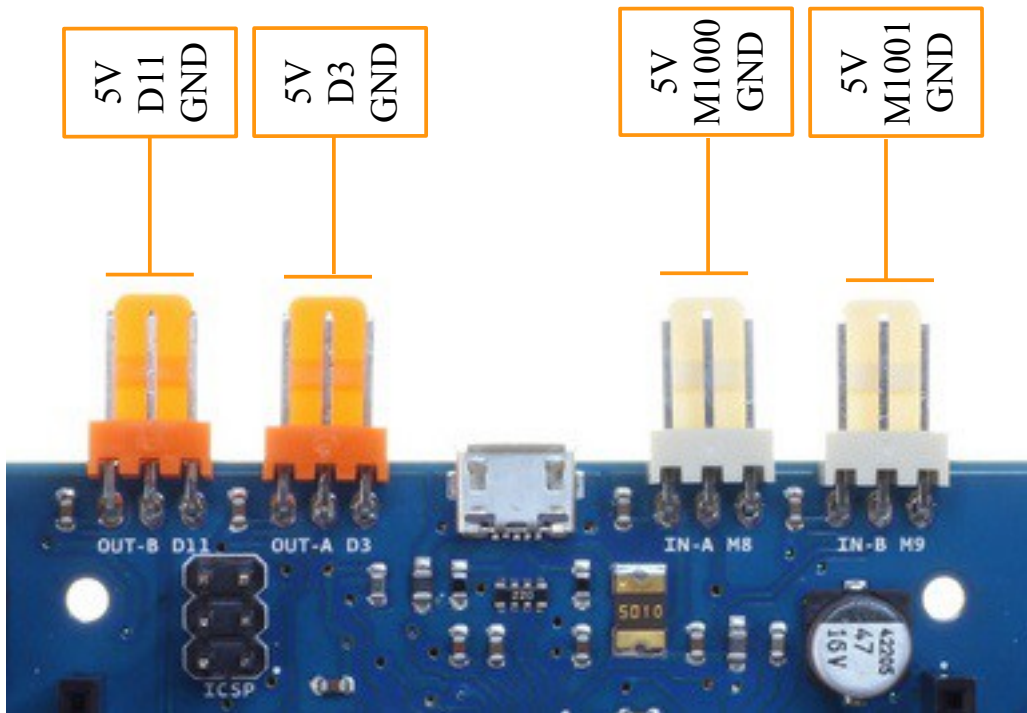

Key

- Dxx** Digital pin xx.
e.g. D12 is digital pin 12
- Axx** Analog pin xx
e.g. A5 is analog pin 5
- Mxxxx** Multiplexer channel xxxx
Because there is too many analog pins for the Esplora to handle naturally we use the in built multiplexer. The multiplexer allows us to use the Esplora's 5 analog pins A0 to A4, to return 13 different analog sensors. This works by setting each of the pins A0 to A3 to either high or low and depending on this combination the multiplexer gives us one of our sensor values on pin A4.
So each x in Mxxxx above can be either 0 or 1. If the first x is 1 we set A3 to high otherwise we set it to low. If the second x is 1 we set A2 to high otherwise we set it to low. If the third x is 1 we set A1 to high otherwise we set it to low. If the fourth x is 1 we set A0 to high otherwise we set it to low. Then we read the value at A5 to get the sensor value.
e.g. M1010 would mean we set A3 to high, A2 to low, A1 to high and A0 to low. Then we read the value at A5 to get the sensor value.
- 5V** Pin provides 5 volts
- GND** The ground pin